



Pro Scale® Advanced Lighting Control System Installation Instructions - 1979 Chevrolet® Blazer® or K10 Truck

Covers Part #8038X

The Traxxas Pro Scale® Advanced Lighting Control System for your 1979 Chevrolet Blazer or K10 Truck consists of two major electronic components: the Pro Scale Lighting Power Module and the Pro Scale Lighting Distribution Block.

The **Lighting Power Module** installs on the chassis and performs as the voltage regulator and power supply for the lighting system. It also controls various lighting functions through the two buttons on the face of the module and communicates with the receiver in the model via the communication cable **or** the optional included MAXX® Link cable.

The **Lighting Distribution Block** mounts in the body of the vehicle and is the distribution hub for all the various wired lights in your Blazer body. Its main function is to direct power and instructions to the brake lights, reverse lights, turn signals, and high/low beam lighting.

There is only one rugged breakaway wiring connector between the **Lighting Distribution Block** and the **Lighting Power Module** for reliable lighting performance, plus it makes it easy to remove the body for vehicle service. The connector is designed to break away from the vehicle, without damage, if the body comes off the vehicle in a crash. There are lighting channels on the **Lighting Power Module** which allow the lighting installed on the chassis to be permanently connected and integrated into the system. This is helpful to install features such as rock lights, bumper lights, and other chassis-mounted accessory lighting.



CAUTION: RISK OF DAMAGE TO BATTERIES!

Always disconnect the battery from the ESC when not in use to prevent the possibility of over-discharge and battery damage.

Kit Contents:

- Pro Scale Lighting Power Module
- Power module chassis mount
- Pro Scale Lighting Distribution Block
- Lighting Distribution Block mount (2)
- Motor sense wire harness
- Breakaway cable (part of the Lighting Distribution Block)
- MAXX® Link cable (Data Link) (TQi Radio System only)
- Receiver communication cable
- Headlight harness assembly
- Reverse lights harness
- Tail lights harness
- Double jumper
- Headlight reflector (2)
- 2.6x8mm button-head cap screw (4)
- 2.5x10mm countersunk cap screw (1)
- 2.5x12mm cap screw (1)
- 2.5x18mm cap screw (1)
- Zip ties (10)
- Zip tie mount (3)
- Double-sided adhesive foam tape
- Silicone grease

Tools required:

- 1.5mm hex wrench (part #3415, sold separately)
- 2.0mm hex wrench (part #3415, sold separately)
- Wire cutters (to trim zip ties)
- Small needle nose pliers

LIGHTING DISTRIBUTION BLOCK

Accessory Connectors
(not used with this kit)

Wiring connectors for the lights are labeled with letters and/or colors.

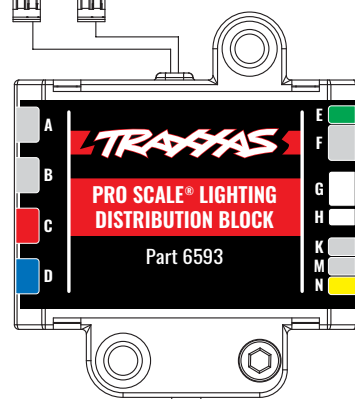

LIGHTING POWER MODULE

to Traxxas XL-5 HV Electronic Speed Control (ESC) or direct battery power source up to 3s LiPo or 12.6V

TOP VIEW

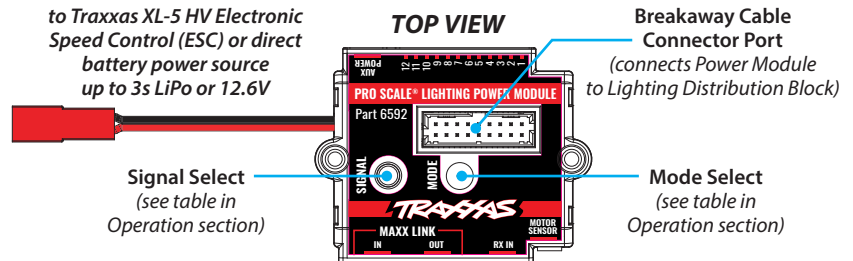

MAXX® Link Cable Ports
(connects power module to receiver using MAXX Link cable)
(TQi Radio System only)

Receiver Communication Cable Port
(connects power module to receiver using receiver communication cable)

Motor Sense Connector Port

Auxiliary Power Connector
(3V - always on)



COMMUNICATION CABLES

Your Pro Scale Advanced Lighting Control System includes two communication cables: the Receiver Communication Cable and the MAXX® Link Cable. Since your model is equipped with the TQi receiver, you can use either the Receiver Communication Cable **or** the MAXX Link Cable. **MAXX® Link Cable only:** The 6511 Traxxas Link Wireless Module (sold separately) is required for Traxxas Link App functionality (only with the MAXX Link Cable). Some models may require a software update for the TQi receiver via the Traxxas Link App for custom lighting controls and configurations (see Appendix on page 7 for additional information).

Only use one of the communication cables to connect the Lighting Power Module to the receiver. Do not use both cables together.



MAXX® Link Cable
(TQi Radio System only)

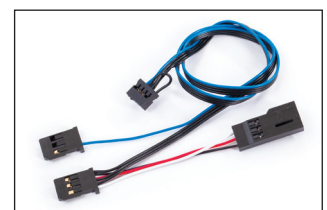

Receiver Communication Cable

A. INSTALL THE LIGHTING POWER MODULE ON THE CHASSIS

1. Install the Power Module mount on the chassis with the included 2.5x10mm countersunk cap screw (Fig. 1).
2. Install the Lighting Power Module on the mount with the included 2.5x12mm (1) and 2.5x18mm (1) cap screws (Fig. 1).
3. Route the module power wire under the mount. Plug the red male connector from the ESC into the red female connector from the power wire (refer to the Chassis Wiring Diagram on page 3 for more detail).

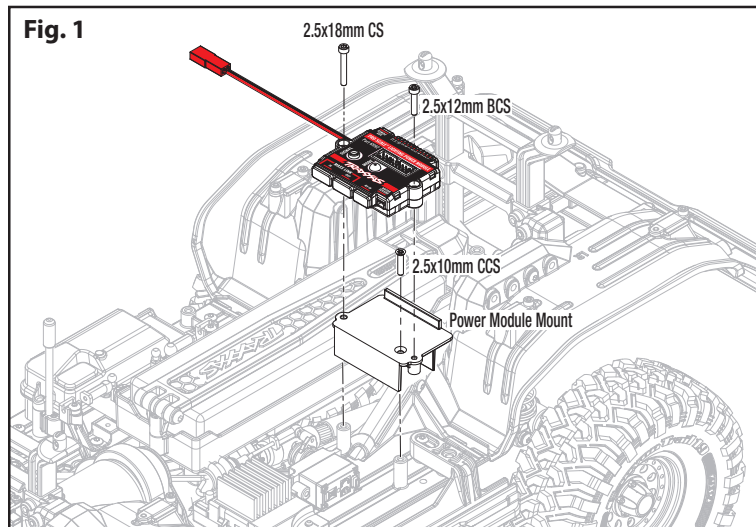

B. WIRE THE LIGHTING POWER MODULE TO THE RECEIVER

1. Plug one end of the Receiver Communication Cable into the RX IN port on the Power Module (Fig. 2) (refer to the Chassis Wiring Diagram on page 3 for more detail).



2. Remove the 3x10mm counter-sunk cap screws (2) from the battery tray (Fig. 3).
3. Lift up the battery tray and route the Receiver Communication Cable from the Power Module under the battery tray and to the receiver box (refer to the Chassis Wiring Diagram on page 3 for more detail). Use a zip tie (included) to attach the wires to the loop on top of the transmission housing. Reinstall and tighten the battery tray screws. **Note: Be careful not to pinch or damage any of the wires under the battery tray.**

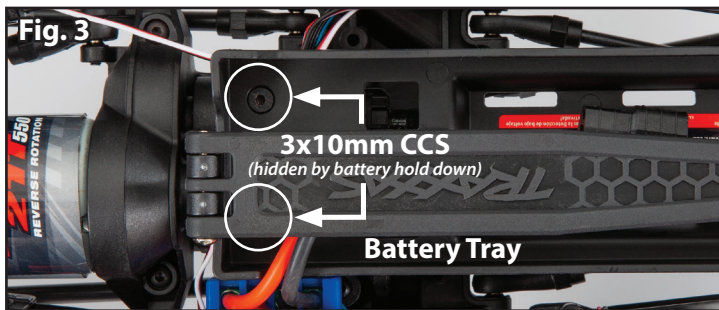

4. Remove the receiver box cover by removing the three 3x8mm button-head cap screws (Fig. 4).
5. Remove the wire clamp by removing the two 2.5x8mm cap screws (Fig. 4).
6. Feed the loose end of the Receiver Communication Cable connector over the wire guide and into the receiver box (Fig. 5). To make installation easier, unplug and remove a few of

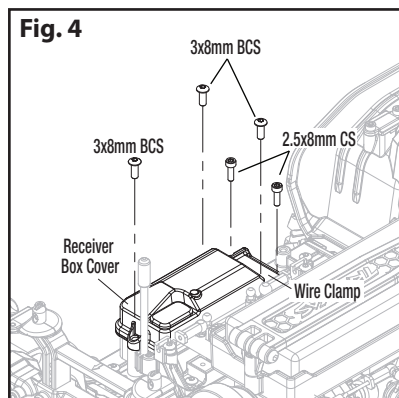

the existing wires from the receiver box. **Note the locations of any unplugged wires.** Use needle nose pliers to help grab the connectors and pull them through. Arrange all wires neatly between the wire guides in the receiver box (Fig. 5).



The excess wire will be bundled inside the receiver box.

7. Apply a bead of the included silicone grease to the wire clamp (Fig. 6).
8. Be careful not to damage the wires (make sure the wires are in the wire guides). Reinstall the wire clamp. Tighten the two 2.5x8mm cap screws securely (Fig. 7).
9. Unplug the electronic speed control (ESC) from the receiver (channel 2).
10. Plug the communication cable into the receiver (Fig. 8): the black connector with the single blue wire plugs into one of the channel 1 ports; the female black connector with the 3 black wires plugs into the channel 2 port.

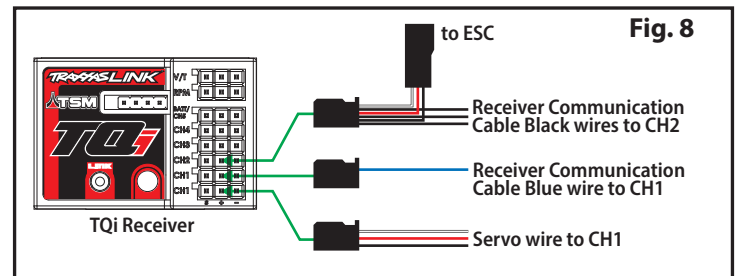
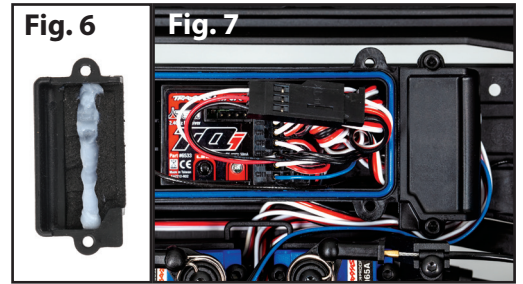

11. Now, plug the black male connector (white, red, black servo cable) from the ESC into the black female connector (white, red, black servo cable) on the communication cable (refer to the Chassis Wiring Diagram on page 3 for more detail). Leave the steering servo cable plugged into the other channel 1 port.
12. Make sure the blue o-ring gasket is properly seated in the groove in the receiver box so that the cover will not pinch it or damage it in any way.
13. Reinstall the cover on the receiver box and tighten the three 3x8mm button-head cap screws securely. Inspect the cover to make sure that the O-ring seal is not visible.
14. Use the supplied zip ties to bundle the wires neatly and attach them to the vehicle as needed so that loose wires will not become entangled with moving parts.

C. INSTALL THE MOTOR SENSE WIRING HARNESS

1. Unplug the red and black motor wires (bullet connectors) from the ESC. Plug the bullet connectors from the motor and the ESC into the motor sense wiring harness (red to red and black to black) (Fig. 9). Plug the harness connector into the Motor Sensor port on the power module (refer to the Chassis Wiring Diagram on page 3 for more detail).



2. Use the supplied zip ties to bundle the wires neatly and attach them to the vehicle as needed so that loose wires will not become entangled with moving parts.



CHASSIS WIRING DIAGRAM

Chassis Wiring (Top Down View)

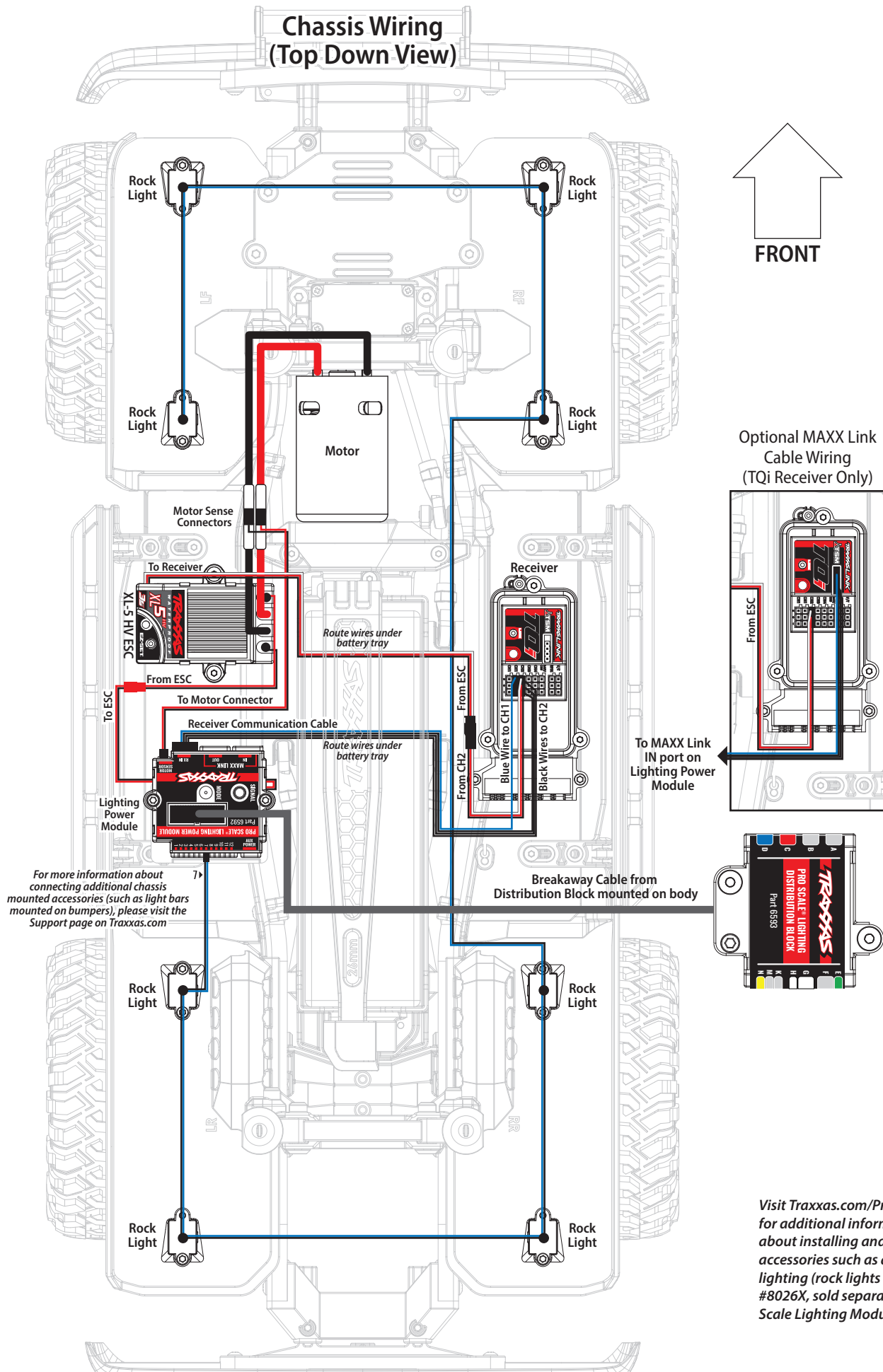

D. INSTALL HEADLIGHTS WIRING HARNESS

1. Remove the 2.5x6mm button-head screw from each headlight assembly and remove the assemblies from the grille (A) (*refer to the Lighting Assembly Diagram below for more detail*). Retain and reuse the plastic headlight mounts and hardware.
2. Install the chrome reflectors (B) onto the circuit boards of the LED headlight harnesses (C) (Fig. 11). **Note:** The reflectors must be installed correctly to sit flat against the circuit boards. Align the keying features (pegs on the reflectors with holes in the circuit boards). Also, there is a notch on the bottom side of the reflectors for clearance of the wires on the circuit boards.
3. Install the circuit boards into the existing plastic headlight mounts (D); then, install the headlight lens (E) over the chrome reflectors and onto the circuit boards (Fig. 12). **Note:** Align the keying features (pegs on the lens with holes in the circuit boards and headlight mounts).

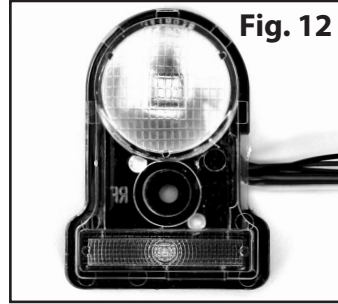

4. Install complete left and right headlight assemblies into the front grille and secure with the 2.5x6mm button-head cap screws removed during disassembly.
5. Insert the front LED side marker lights into the receptacles near each headlight. Be careful not to damage the wires. The LEDs should snap into place.
6. Route the wiring harnesses in the body (*refer to the Body Wiring Diagram on page 6 for more detail*). Use the included zip ties and zip tie mounts to secure the wiring to the body in the locations indicated. The zip ties do not need to be tight; allow some extra length for wire movement. Use wire cutters to trim zip ties.

E. INSTALL TAIL LIGHTS AND REVERSE LIGHTS WIRING HARNESS

- Note:** The tail lights harness and reverse lights harness have a long and short wire lead. The short wire of each harness should be installed on the left side (driver side) of the vehicle body. The tail lights harness has the larger 5mm LEDs with the red color band near the connector. The reverse lights harness has the smaller 3mm LEDs with a letter "A" indicator band near the connector.
1. Insert the LEDs on the reverse lights harness into the reverse light receptacles. Be careful not to damage the wires. The LEDs should snap into place.
 2. Insert the LEDs on the tail lights harness into the tail light receptacles. The LEDs should snap into place.
 3. Route the wiring harnesses in the body (*refer to the Body Wiring Diagram on page 6 for more detail*). Use the included zip ties and zip tie mounts to secure the wiring to the body in the locations indicated. The zip ties do not need to be tight; allow some extra length for wire movement. Use wire cutters to trim zip ties.

LIGHTING ASSEMBLY DIAGRAM

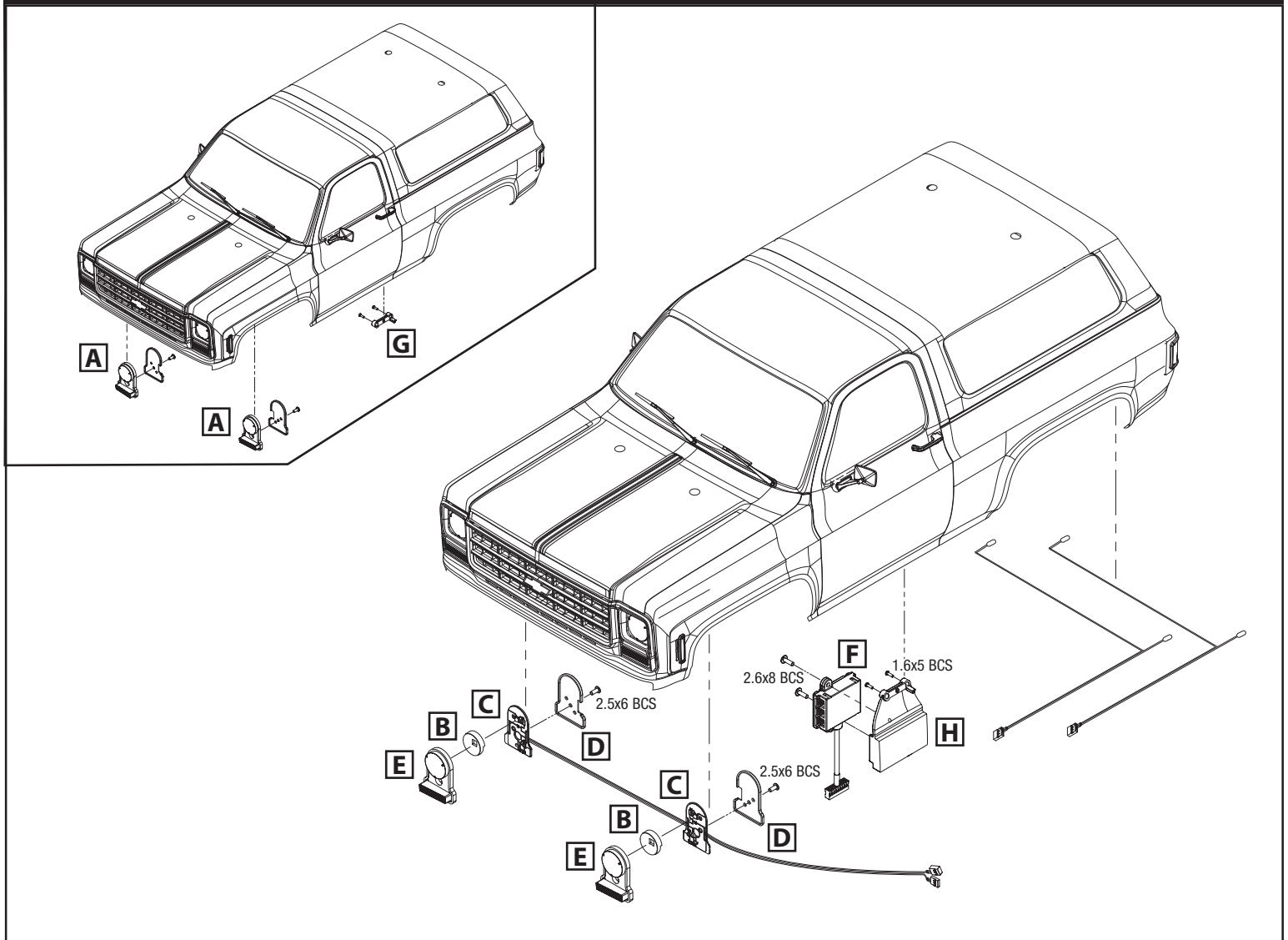
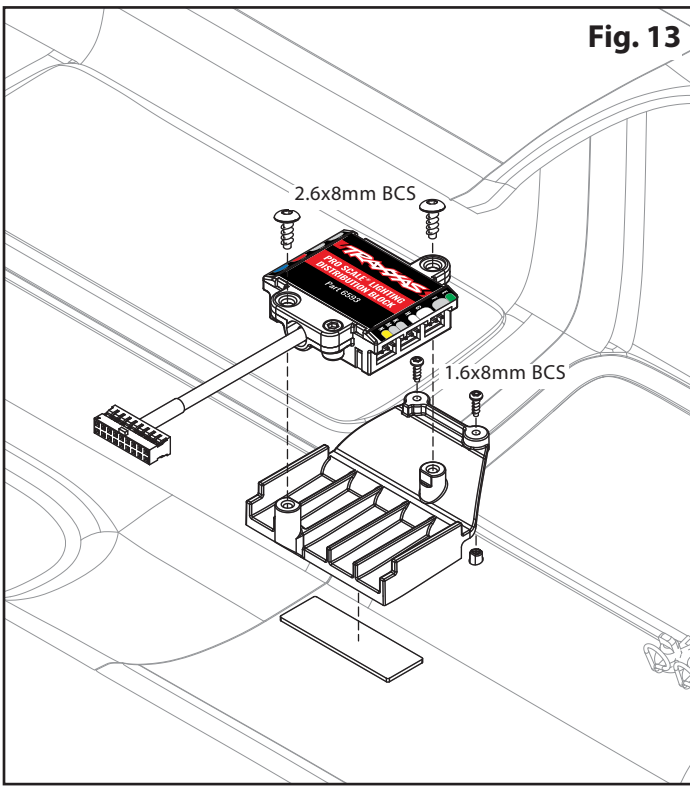

Fig. 13



F. INSTALL THE LIGHTING DISTRIBUTION BLOCK Blazer

1. Plug all LED light wire harness connectors into the ports on the Lighting Distribution Block. Match the color band and/or letter indicator on the wire harnesses with the corresponding color/letter of each port on the Lighting Distribution Block (*refer to the Lighting Distribution Block port chart below for more detail*).
2. Install the included double jumper into port F on the Lighting Distribution Block.
3. Remove the 1.6x5mm button-head screws (2) from the driver side (left side) door handle mount (G). Remove the mount.
4. Peel the backing from the included adhesive foam tape and attach it to the flat surface on the back of the Lighting Distribution Block mount (Fig. 13). *Do not remove the backing from the other side of the tape yet.*
5. Install the Distribution Block mount and secure with the 1.6x5 mm button-head screws (2) as shown in Fig. 13.
6. Gently flex the body away from the Lighting Distribution Block mount and remove the backing from the other side of the foam tape. Press the body against the mount to adhere it to the mount.
7. Use the included 2.6x8mm button-head screws (2) to secure the Lighting Distribution Block to the mount (Fig. 13).
8. Plug the breakaway cable from the Lighting Distribution Block into the connector on top of the Power Module before installing the vehicle body (Fig. 15).

Fig. 14

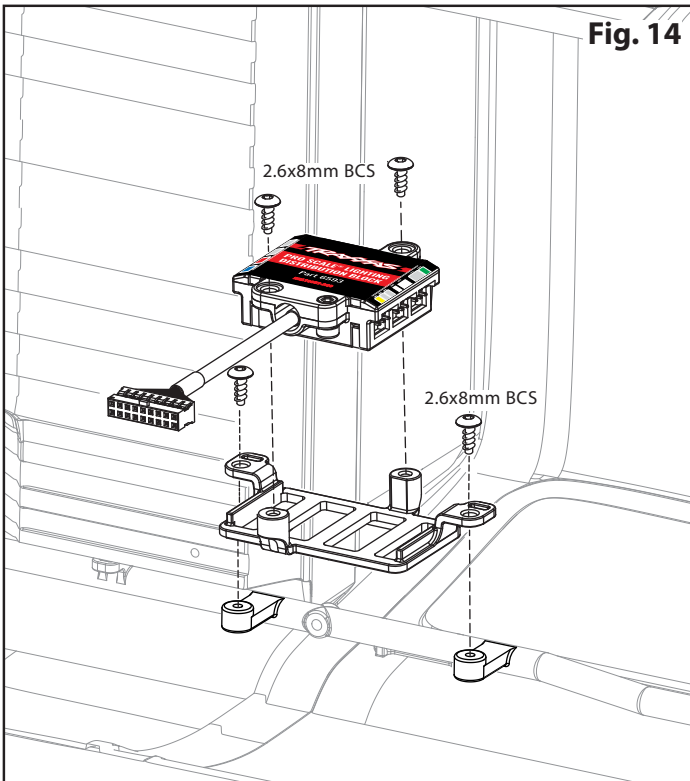

G. INSTALL THE LIGHTING DISTRIBUTION BLOCK K10 Truck

1. Plug all LED light wire harness connectors into the ports on the Lighting Distribution Block. Match the color band and/or letter indicator on the wire harnesses with the corresponding color/letter of each port on the Lighting Distribution Block (*refer to the Lighting Distribution Block port chart below for more detail*).
2. Install the included double jumper into port F on the Lighting Distribution Block.
3. Install the Distribution Block mount and secure with the included 2.6x8mm button-head screws (2) as shown in Fig. 14.
4. Use the included 2.6x8mm button-head screws (2) to secure the Lighting Distribution Block to the mount (Fig. 14).
5. Plug the breakaway cable from the Lighting Distribution Block into the connector on top of the Power Module before installing the vehicle body (Fig. 15).

Fig. 15



Breakaway Cable from Lighting Distribution Block

LIGHTING DISTRIBUTION BLOCK LED LIGHT HARNESS PORTS

Letter	Color	Description	Function
A	N/A	Reverse light harness	Back up light LEDs when vehicle is put in reverse
C	Red	Tail light harness	Tail lights, brake lights, and rear integrated turn signal LEDs
F	N/A	Rear integrated turn signal jumper	Install jumper when using rear integrated turn signals (single red LED for tail, stop, and turn)
G	White	Headlight assembly harness	Headlights and front marker light LEDs
H	White	Front turn signal harness	Front turn signal light LEDs

Accessory Connectors (not used with this kit)

Wiring connectors for the lights are labeled with letters and/or colors.

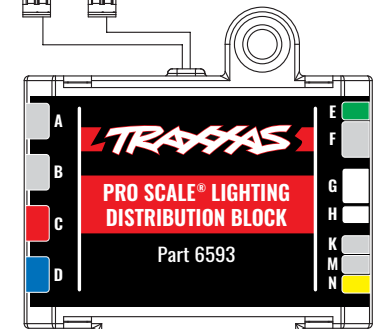

BODY WIRING DIAGRAM

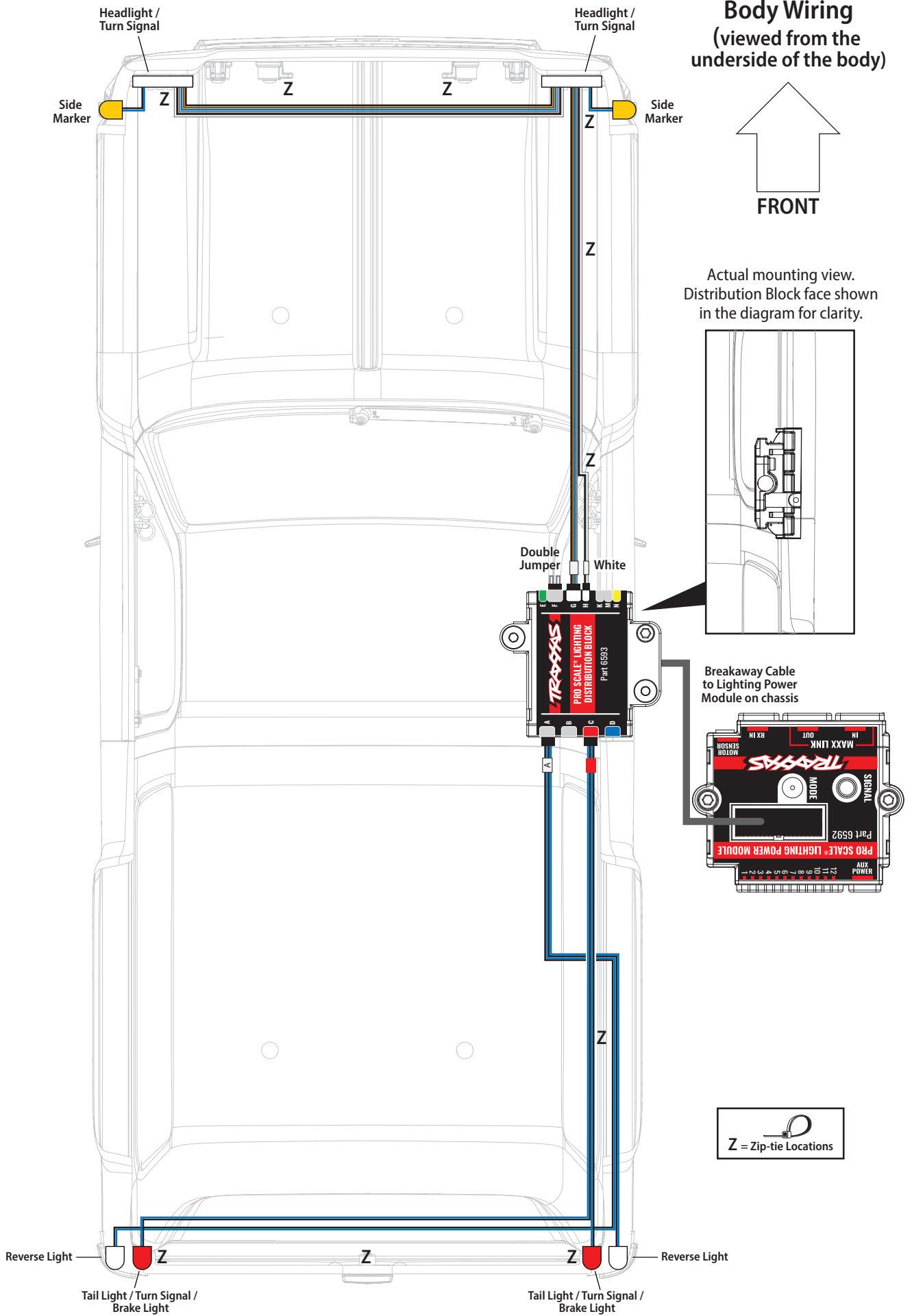

LIGHTING CONTROL SYSTEM OPERATION

HEADLIGHTS MODE SELECTION

Use the **Mode** button on the Pro Scale Lighting Power Module to cycle through the different lighting modes (from **Low Beam Mode** to **High Beam Mode** to **Daytime Mode**).

HAZARD LIGHTS

Use the **Signal** button on the Pro Scale Lighting Power Module to turn the hazard lights on or off.

TURN SIGNALS

The turn signals are activated by default. To deactivate the turn signals, press and release the **Signal** button on the Pro Scale Lighting Power Module two times quickly. Both left turn signal LEDs will blink once, and then both right turn signals LEDs will blink once to indicate that the turn signals are deactivated.

To reactivate the turn signals: Press and release the **Signal** button two times again quickly. Both left turn signal LEDs will blink twice, and then both right turn signals LEDs will blink twice to indicate that the turn signals are activated.

TURN SIGNAL OPERATION

With the vehicle stopped, turn the steering wheel on the transmitter (left or right) to turn on the LEDs. The turn signal LEDs will continue to flash while the steering wheel is turned in this same direction or remains centered. Turn the steering wheel in the opposite direction to cancel the turn signal.

	Selection	Action
Mode	Low Beam Headlights	Default
	High Beam Headlights	Press and release Mode
	Daytime Headlights (off)	Press and release Mode once again

	Selection	Action
Signal	Hazard Lights On	Press and release Signal once
	Hazard Lights Off	Press and release Signal once again
	Deactivate Turn Signals	Press and release Signal 2x quickly
	Activate Turn Signals	Press and release Signal 2x quickly again

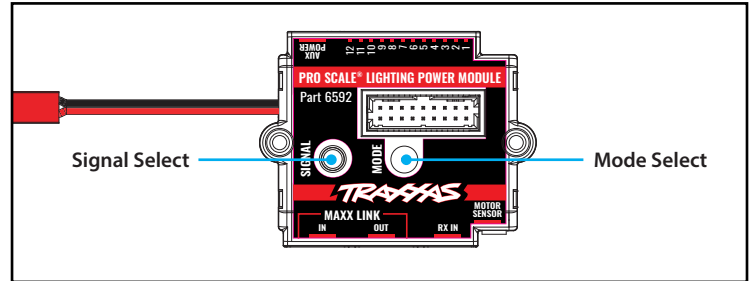

APPENDIX

WIRING DIAGRAM WITH RECEIVER COMMUNICATION CABLE AND HIGH-OUTPUT EXTERNAL BEC (part #2262, sold separately)

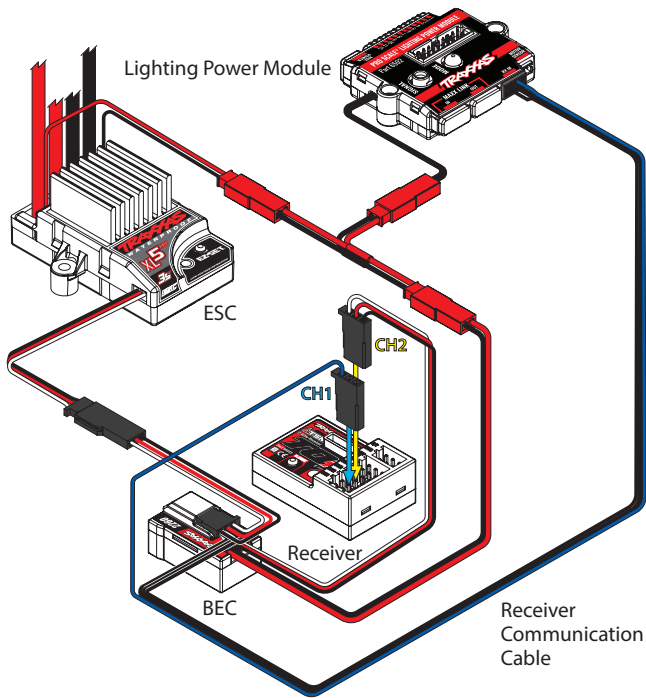

WIRING DIAGRAM WITH OPTIONAL MAXX® LINK CABLE AND HIGH-OUTPUT EXTERNAL BEC (part #2262, sold separately)

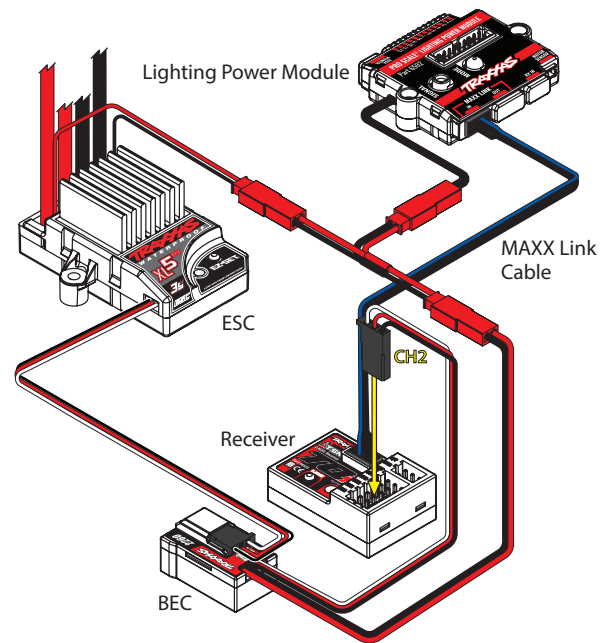

Important: To prevent possible damage to the electronics while using an external BEC, do not connect **both** the MAXX Link Cable and Receiver Communication Cable to the Lighting Power Module at the same time.

OPTIONAL MAXX LINK CABLE WIRING

Use the optional included MAXX Link Cable to connect the Lighting Power Module to the receiver.

DO NOT use the Receiver Communication Cable with the MAXX Link Cable. The MAXX Link Cable is designed to work with the Traxxas Link™ Wireless Module (part #6511, sold separately) to provide Traxxas Link App functionality for custom lighting controls and configurations.

Your model may require a software update for the TQi receiver via the Traxxas Link App (Traxxas Link Wireless Module required).



Traxxas Link Wireless Module (part #6511, sold separately)

Plug the MAXX Link cable into the **MAXX Link IN** port on the Lighting Power Module. Use the same wire routing from the Lighting Power Module and into the receiver box as shown in the Receiver Communication Cable Installation instructions. Plug the loose end of the cable into the expansion port on the receiver.

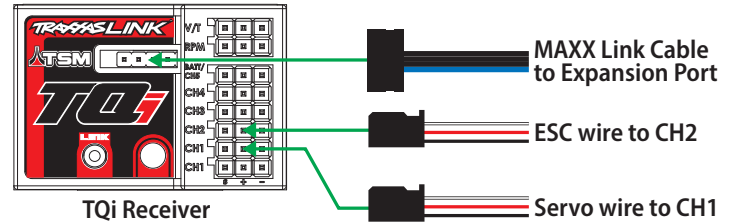

WARRANTY

Warranty Information

Traxxas electronic components are warranted to be free from defects in materials and workmanship for a period of 30 days from the date of purchase.

Limitations: Any and all warranty coverage does not cover replacement of parts and components damaged by abuse, neglect, improper or unreasonable use, crash damage, water or excessive moisture, chemical damage, improper or infrequent maintenance, accident, unauthorized alteration or modification or items that are considered consumable. Traxxas will not pay for the cost of shipping or transportation of a defective component to us.

Traxxas Lifetime Electronics Warranty

After the expiration date of the warranty period, Traxxas will repair electronic components for a flat rate. Please visit Traxxas.com/support for a current schedule of warranty costs and fees. The covered repairs are limited to non-mechanical components that have NOT been subjected to abuse, misuse, or neglect. Products damaged by intentional abuse, misuse, or neglect may be subject to additional charges. Traxxas liability, in no case, shall be greater than the actual purchase price of this product. For replacement, product must be returned in brand new condition, with packaging and itemized sales receipt.



Download and install the latest firmware updates, change the module settings, and gain access to additional functions using the Traxxas Link App (available in the Apple App StoreSM or on Google PlayTM). The TQi transmitter with the Traxxas Link Wireless Module (part #6511, sold separately) are required.



This device complies with FCC Part 15 & IC RSS-210 rules subject to the following conditions: 1) This device may not cause harmful interference, and 2) This device must accept all interference received, including interference that may cause undesired operation.

For patent and patent-pending information, please visit Traxxas.com/pat

App Store is a service mark of Apple Inc. Google Play is a trademark of Google Inc. Chevrolet[®] and Blazer[®] are trademarks of General Motors. All copyrights and trademarks are used by Traxxas under license.